

# DALTON

**"OSD" OVERLOAD SAFETY DEVICES**  
**TORQUE LIMITERS—COUPLINGS**

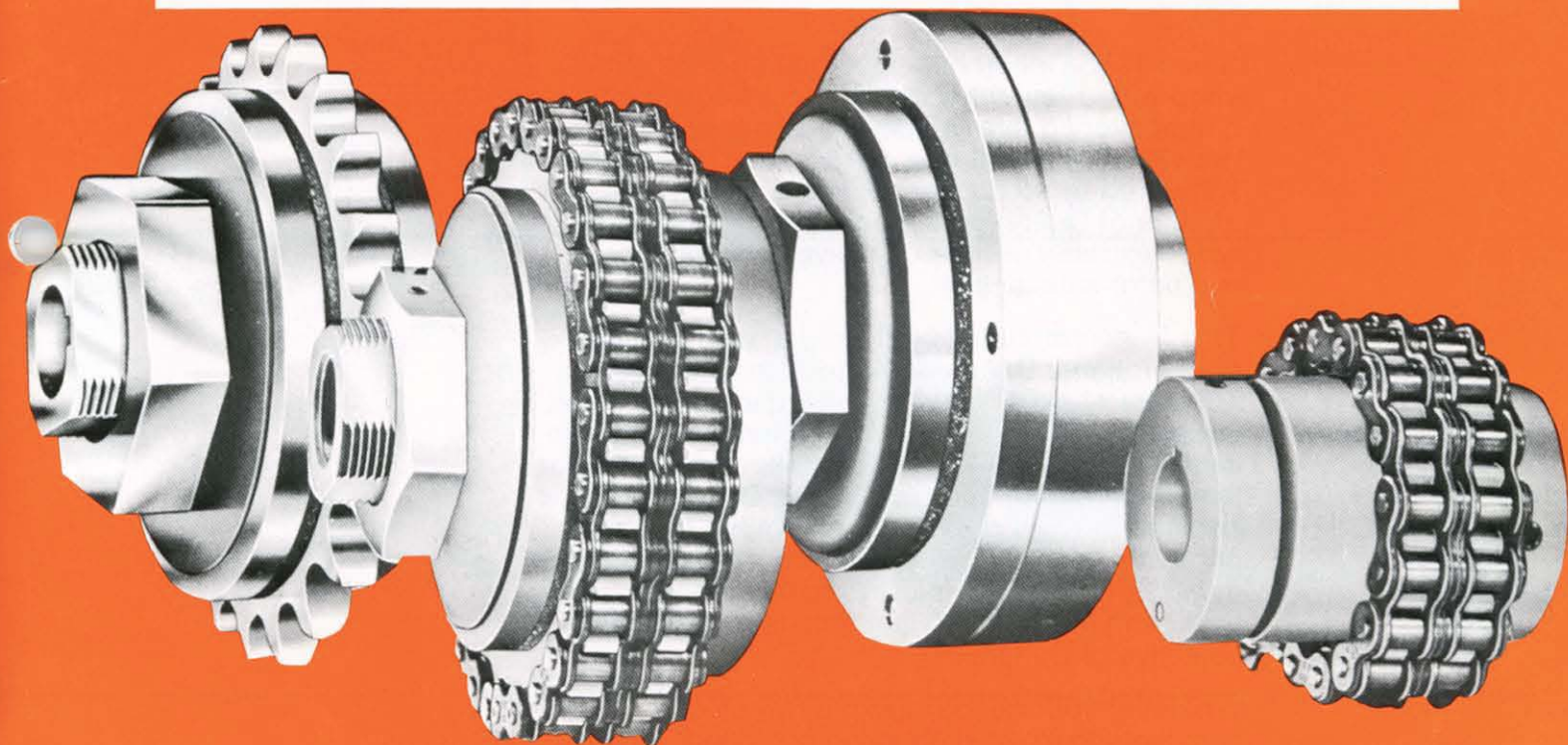

**DALTON** gear company

212 COLFAX AVENUE N., MINNEAPOLIS, MINN. 55405



the  
**DALTON**  
gear company

**dedicated to  
precision manufacturing  
of gears, sprockets, couplings,  
torque limiters, speed reducers  
and gearmotors**

Since 1955 Dalton has developed from a small shop with a few machines to a fully equipped plant covering over 50,000 square feet. This growth is the result of a combination of skill and know-how in production, plus the special attitude of Dalton personnel and management which focuses on one objective...complete customer satisfaction.

This Dalton attitude is reflected in every phase of operations. Dalton management, with over 45 years of experience in serving industry, understands the needs and problems of both distributors and O.E.M. customers and what they expect from a manufacturer. Dalton engineering and production personnel take real pride in producing products of consistent high quality that adhere rigidly to specifications. Doing the job right the first time is the everyday objective of Dalton.

Whatever your needs...from a few stock sprockets to mass production of highly specialized gears...you can depend on Dalton for the quality you expect, the delivery you require, and the best possible price.

**DALTON** gear company

212 Colfax Avenue North  
612/374-2150  
www.daltongear.com

• Minneapolis, Minnesota 55405  
Toll Free No. 1-800-328-7485  
FAX Number 612-374-2467

# DALTON OVERLOAD SAFETY DEVICES(OSD)

BASIC "OSD"  
SAFETY  
DEVICES  
Pages 4-5



Patent No.  
3,092,983  
(Torque Limiters)

"OSDC"  
OVERLOAD  
SAFETY  
DEVICE  
COUPLINGS  
Pages 6-7



Patent No.  
2,659,220  
(Torque Limiters)

"ROSDC"  
RIGID  
OVERLOAD  
SAFETY  
DEVICE  
COUPLINGS  
Pages 8-9



Patent  
Applied for  
(Torque Limiters)

ROLLER  
CHAIN  
SHEAR  
PIN  
COUPLINGS  
Page 12



Patent  
Applied for

ROLLER  
CHAIN  
FLEXIBLE  
COUPLINGS  
Page 13

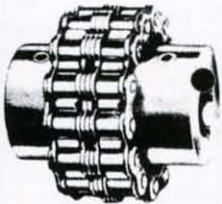

RIGID  
STEEL  
COUPLINGS  
Page 10



SPECIAL SPROCKETS  
for  
DALTON  
TORQUE LIMITERS  
Pages 10-11



SAFETY  
OVERLOAD  
SWITCH  
Pages 14-15

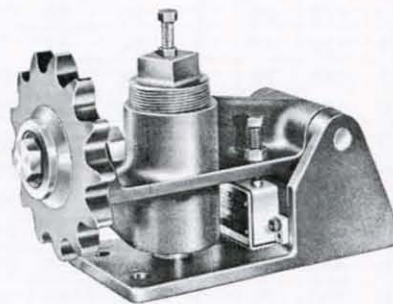

Dalton "OSD" Torque Limiters give longer life for the following reasons:

- |                         |  |
|-------------------------|--|
| 1—High carbon steel hub | 5—Chrome vanadium steel Belleville springs                 |
| 2—Steel pressure plate  | 6—Single hex nut of alloy steel for uniform torque         |
| 3—Precision machining   | 7—Ratings based on a safety factor of 33%                  |
| 4—Roller Bearings       | 8—Sprockets ground to approximately a 32 micro inch finish |

These features add up to better performance and longer life.

No other torque limiter can equal the performance and long life.

***SERVICE PROVEN IN ALMOST EVERY  
MAJOR INDUSTRIAL COMPANY.***

# DALTON MODEL "OSD"

## OVERLOAD SAFETY DEVICE

The Dalton "OSD" is a torque-limiter unit which prevents costly breakdowns when equipment is overloaded by disengaging when a set maximum load is reached. The unit is re-engaged immediately when the overload is eliminated. The "OSD" is easily adjusted with a torque-wrench to the specific torque required. It can be used with a sprocket, gear, belt-pulley, or flange.

The clutch facings used have been selected after research and testing to resist expansion due to moisture. The flanges are high carbon steel machined accurately for precise operation. The threaded hub and pressure plate are machined square and ground where necessary to position the plate and eliminate extra parts. The torque adjusting nut is hexagonal for easier installation and adjustment. Equipped with needle bearings to eliminate shaft scoring, seizing and wear. Use only specially ground sprockets see pages 10 & 11.

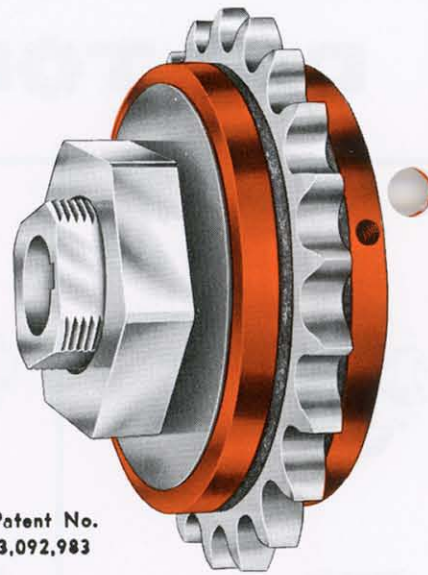

Patent No. 3,092,983

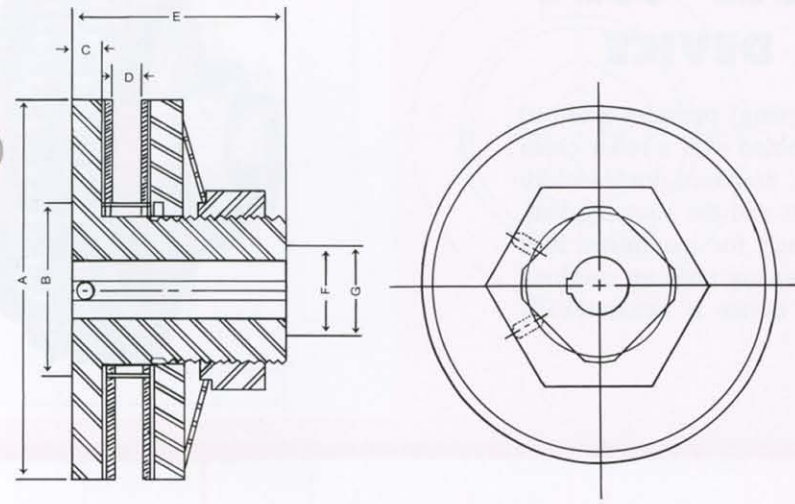

FIBERS ARE 1/8" THICK

The Dalton "OSD", Overload Safety Device Unit, is equipped with a single torque adjusting nut for torque uniformity. Only one setting on the single nut applies equal pressure on the entire unit, whereas the use of multiple nuts would make it extremely difficult to equalize the pressure and would defeat the purpose of a positive release. A standard pipe wrench, which is readily available everywhere, may also be used to adjust this nut.

Clutch No.	Weight		Maximum Torque Ft.-mtp		No. of Springs	(A) Flange O.D.		(B) O.D. of Bearing and Sprocket Bore		(C) Thickness of Flange		(D) Minimum Width Between Fibers		(D <sub>1</sub> ) Maximum Width for Sprocket or Pulley		(D <sub>2</sub> )**		(E) Over All Length		Torrington Bearing No.	(F) Minimum Bore		(G) Maximum Bore		Min. Plain Bore Price	Finished Bore with K.W. & S.S.		Price	Finished Bore with K.W. & S.S.		Price	For Bore Sizes Not Shown, Add Charge To This List ←	Clutch No.
	Lbs.	kg	Lbs.	mtp		In.	mm	In.	mm	In.	mm	In.	mm	In.	mm	In.	mm	In.	mm		In.	mm	In.	mm		In.	mm		In.	mm			
OSD-131	1/4	.11	6	1	1	1 5/16"	33	13 3/16"	20.6	1/4"	6	1/16"	1.5	1 1/32"	7	1/4"	6	1 3/8"	35	B-105	1/4"	6.4	3/8"	10	50.00	1/4"	\$ 52.00	5/16", 3/8"	\$ 58.00	\$16.00	OSD-131		
OSD-131D	1/4	.11	12	2	2	1 5/16"	33	13 3/16"	20.6	1/4"	6	1/16"	1.5	5/16"	8	1/4"	6	1 3/8"	35	B-105	1/4"	6.4	3/8"	10	60.00	1/4"	62.00	5/16", 3/8"	68.00	16.00	OSD-131D		
OSD-225	1	.45	35	5	1	2 1/4"	57	1 1/4"	31.7	3/8"	10	1/16"	1.5	1/2"	13	7/16"	11	2"	51	B-168	3/8"	9.6	3/4"	19	69.00	3/8", 1/2"	72.00	5/8", 3/4"	84.00	16.00	OSD-225		
OSD-225D	1	.45	50	7	2	2 1/4"	57	1 1/4"	31.7	3/8"	10	1/16"	1.5	5/32"	11.9	7/16"	11	2"	51	B-168	3/8"	9.6	3/4"	19	85.00	3/8", 1/2"	88.00	5/8", 3/4"	100.00	16.00	OSD-225D		
OSD-256	1 3/4	.79	50	7	1	2 9/16"	65	1 1/2"	38.1	3/8"	10	1/16"	1.5	7/16"	11	7/16"	11	2"	51	B-208	3/8"	9.6	7/8"	22	88.00	3/8", 1/2"	92.00	5/8", 3/4", 7/8"	106.00	16.00	OSD-256		
OSD-256D	1 3/4	.79	75	11	2	2 9/16"	65	1 1/2"	38.1	3/8"	10	1/16"	1.5	13/32"	10.3	7/16"	11	2"	51	B-208	3/8"	9.6	7/8"	22	106.00	3/8", 1/2"	110.00	5/8", 3/4", 7/8"	124.00	16.00	OSD-256D		
OSD-337	3 3/4	1.70	100	14	1	3 3/8"	86	1 7/8"	47.6	3/8"	10	1/8"	3	1/2"	13	7/16"	11	2 1/8"	54	B-248	1/2"	12.7	1"	25	107.50	1/2", 5/8"	112.00	3/4", 7/8", 1"	128.00	16.00	OSD-337		
OSD-337D	3 3/4	1.70	175	24	2	3 3/8"	86	1 7/8"	47.6	3/8"	10	1/8"	3	7/16"	11	7/16"	11	2 1/8"	54	B-248	1/2"	12.7	1"	25	127.50	1/2", 5/8"	132.00	3/4", 7/8", 1"	148.00	16.00	OSD-337D		
OSD-362	4	1.81	120	17	1	3 5/8"	92	2"	50.8	3/8"	10	1/8"	3	1/2"	13	7/16"	11	2 1/8"	54	B-268	1/2"	12.7	1 1/8"	28	128.00	1/2", 5/8", 3/4"	132.00	7/8", 1", 1 1/8"	148.00	20.00	OSD-362		
OSD-362D	4	1.81	185	26	2	3 5/8"	92	2"	50.8	3/8"	10	1/8"	3	7/16"	11	7/16"	11	2 1/8"	54	B-268	1/2"	12.7	1 1/8"	28	150.70	1/2", 5/8", 3/4"	156.00	7/8", 1", 1 1/8"	172.00	20.00	OSD-362D		
OSD-450	6	2.70	190	26	1	4 1/2"	114	2 1/4"	57.1	7/16"	11	3/16"	5	7/8"	22	7/16"	11	2 7/8"	73	B-308	3/4"	19.1	1 3/8"	35	146.00	3/4", 1", 1 1/8"	152.00	1 1/4", 1 3/8"	168.00	20.00	OSD-450		
OSD-450D	6	2.70	285	39	2	4 1/2"	114	2 1/4"	57.1	7/16"	11	3/16"	5	13/16"	20.6	7/16"	11	2 7/8"	73	B-308	3/4"	19.1	1 3/8"	35	174.00	3/4", 1", 1 1/8"	180.00	1 1/4", 1 3/8"	196.00	20.00	OSD-450D		
OSD-493	6 1/2	2.95	210	29	1	4 15/16"	125	2 5/8"	66.67	7/16"	11	5/16"	8	15/16"	23.8	1 1/16"	17.5	2 7/8"	73	B-3612	3/4"	19.1	1 5/8"	42	189.00	3/4", 1", 1 1/8"	196.00	1 1/4", 1 3/8", 1 1/2", 1 5/8"	214.00	22.00	OSD-493		
OSD-493D	6 1/2	2.95	360	50	2	4 15/16"	125	2 5/8"	66.67	7/16"	11	5/16"	8	7/8"	22	1 1/16"	17.5	2 7/8"	73	B-3612	3/4"	19.1	1 5/8"	42	218.00	3/4", 1", 1 1/8"	225.00	1 1/4", 1 3/8", 1 1/2", 1 5/8"	243.00	22.00	OSD-493D		
OSD-600	10	4.50	320	44	1	6"	152	2 7/8"	73.0	1/2"	13	5/16"	8	13/16"	20.6	1 1/16"	17.5	3"	76	NB-4012	1"	25.4	1 3/4"	44	232.00	1", 1 1/4"	240.00	1 3/8", 1 1/2", 1 5/8"	260.00	22.00	OSD-600		
OSD-600D	10	4.50	440	61	2	6"	152	2 7/8"	73.0	1/2"	13	5/16"	8	3/4"	19	1 1/16"	17.5	3"	76	NB-4012	1"	25.4	1 3/4"	44	262.00	1", 1 1/4"	270.00	1 3/8", 1 1/2", 1 5/8"	290.00	22.00	OSD-600D		
OSD-750	21	8.20	550	76	1	7 1/2"	191	4"	101.6	1/2"	13	3/8"	10	13/16"	30	1 7/16"	17.5	3 3/4"	95	B-5612	1"	25.4	2 1/2"	64	346.00	1", 1 1/2"	360.00	1 3/4", 1 15/16", 2"	384.00	26.00	OSD-750		
OSD-750D	21	8.20	775	107	2	7 1/2"	191	4"	101.6	1/2"	13	3/8"	10	1 1/8"	28.5	1 1/16"	17.5	3 3/4"	95	B-5612	1"	25.4	2 1/2"	64	378.00	1", 1 1/2"	392.00	1 3/4", 1 15/16", 2"	416.00	26.00	OSD-750D		
OSD-900	39	12.70	1000	139	1	9"	229	5"	127.0	5/8"	16	1/2"	13	1 3/8"	35	1 5/16"	23.8	4 1/4"	108	BRONZE BUSHING	1 1/4"	31.8	3 1/2"	90	876.00	1 1/4", 1 3/4"	912.00	2", 2 1/4", 2 3/4"	960.00	52.00	OSD-900		
OSD-900D	39	12.70	1250	173	2	9"	229	5"	127.0	5/8"	16	1/2"	13	1 5/16"	33	1 5/16"	23.8	4 1/4"	108	BRONZE BUSHING	1 1/4"	31.8	3 1/2"	90	940.00	1 1/4", 1 3/4"	976.00	2", 2 1/4", 2 3/4"	1024.00	52.00	OSD-900D		

\*For maximum bore on OSD225, 225D, a shallow keyway is used of 1/2 standard depth. Use the next larger size "OSD" unit when a standard keyway is desired.

\*\*IMPORTANT. Be sure to specify when sprocket or driving member width is in excess of D<sub>2</sub> dimension. Special fibers to suit will be furnished.

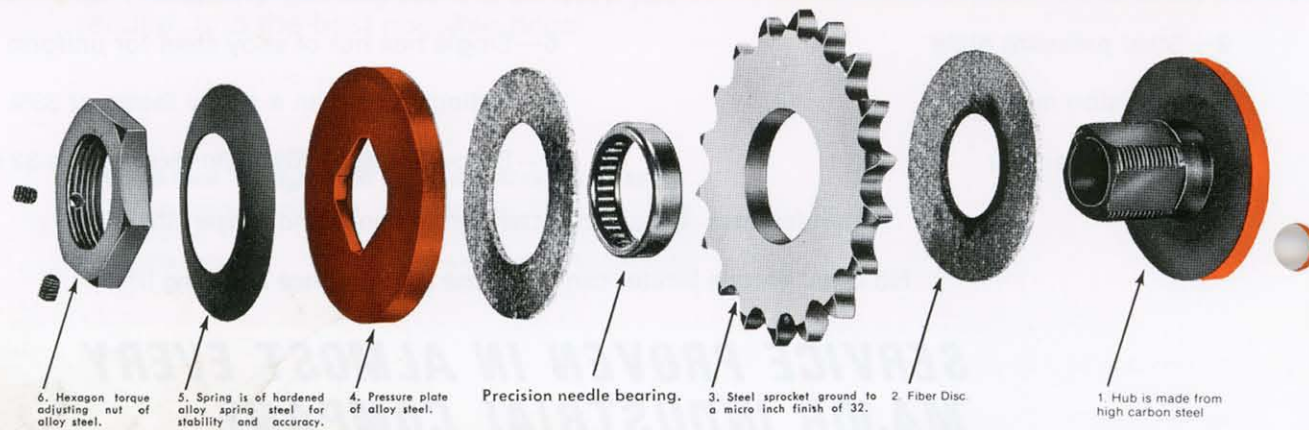

6. Hexagon torque adjusting nut of alloy steel. 5. Spring is of hardened alloy spring steel for stability and accuracy. 4. Pressure plate of alloy steel. Precision needle bearing. 3. Steel sprocket ground to a micro inch finish of 32. 2. Fiber Disc. 1. Hub is made from high carbon steel.

### IMPORTANT NOTES:

The chart shown above is for stock sizes. The "OSD" overload safety device can be made to suit your application. Send us your blueprints or specifications for recommendations by our engineering department.

Dalton Overload Safety Devices can be plated with cadmium, chrome and zinc. Sprockets can be furnished in ferrous materials.

See pages 10 & 11 for sprocket sizes bore tolerances and minimum tooth sprockets.

### PARTS LIST FOR "OSD"

	OSD-131	OSD-225	OSD-256	OSD-337	OSD-362	OSD-450	OSD-493	OSD-600	OSD-750	OSD-900
HUB	21.50	40.00	48.00	59.00	65.00	76.00	94.40	117.00	202.00	620.00
FIBRE (EA)	6.50	8.00	10.40	13.00	14.00	16.00	19.50	23.50	40.00	80.00
PRESSURE PLATE	12.00	16.00	21.00	26.50	28.50	32.00	46.50	64.00	74.00	186.00
SPRING	16.00	21.50	23.00	26.50	31.00	37.00	37.50	40.00	42.50	84.80
NUT	9.20	10.60	14.50	19.00	20.00	21.50	30.00	40.00	63.50	132.50
BEARING	5.30	8.00	10.00	12.70	18.50	24.70	31.00	38.00	60.55	96.00

# DALTON MODEL "OSDC" OVERLOAD SAFETY DEVICE

The Dalton OSDC (Overload Safety Device Coupling) provides overload protection through the use of an OSD unit combined with a roller chain coupling half counterbored to fit the OSD flange. Standard double-width roller chain is used to couple the basic OSD unit and the coupling half.

The OSDC can be set with a torque wrench for maximum load desired. The unit functions as a roller chain coupling until an overload occurs, causing the OSDC to dis-engage. The device is automatically re-engaged when the overload is eliminated.

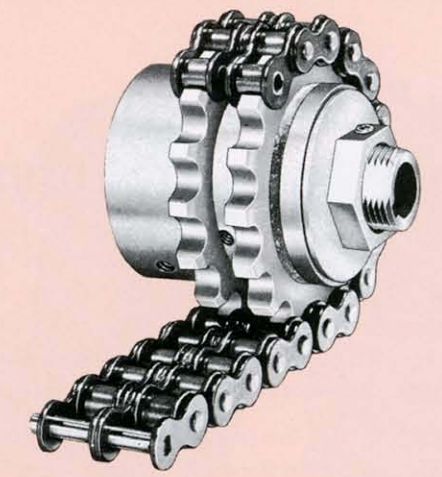
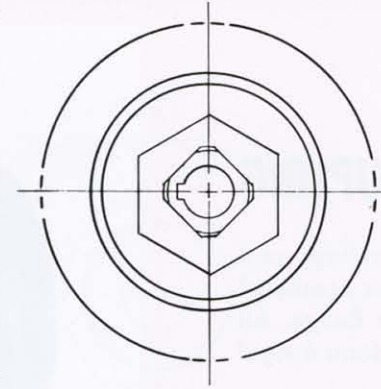
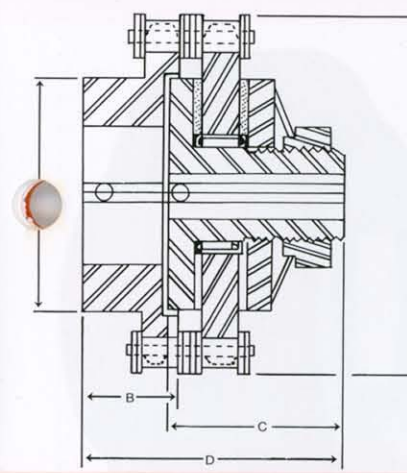
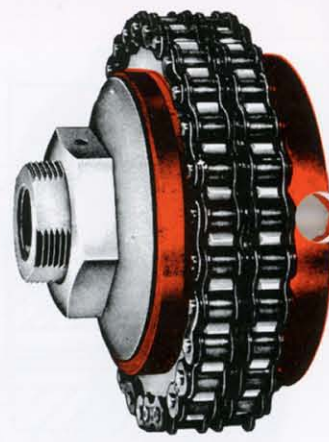

Coupling No.	Weight		Max. Torque Ft.		No. of Springs	Maximum Bore		Minimum Bore		Coupling Half No.	OSD Sprocket No.	Coupling Chain No.	OSD Half	Coupling Half	Price	Not Shown, Add Charges to This List Per Half	A		B		C		D		E			
	Lbs.	kg	Lbs.	mkp		In.	mm	In.	mm								In.	mm	In.	mm	In.	mm	In.	mm	In.	mm	In.	mm
OSDC-131	2	.90	6	1	1	3/4"	20	3/8"	10	1/4"	6.4	1/4"	6.4	3517A	35A17GC	D35	146.00	\$ 16.00	2.390"	61	1 1/32"	30	1 3/8"	35	2 3/8"	60	1 21/32"	42
OSDC-131D	2	.90	12	2	2	3/4"	20	3/8"	10	1/4"	6.4	1/4"	6.4	3517A	35A17GC	D35	158.00	16.00	2.390"	61	1 1/32"	30	1 3/8"	35	2 3/8"	60	1 21/32"	42
OSDC-225	4	1.80	35	5	1	1 1/2"	40	3/4"	19	3/8"	9.6	3/8"	9.6	4020A	40A20GC	D40	172.00	16.00	3.656"	93	1 1/8"	29	2"	51	2 29/32"	74	2 11/16"	68
OSDC-225D	4	1.80	50	7	2	1 1/2"	40	3/4"	19	3/8"	9.6	3/8"	9.6	4020A	40A20GC	D40	188.00	16.00	3.656"	93	1 1/8"	29	2"	51	2 29/32"	74	2 11/16"	68
OSDC-256	5 1/2"	2.47	50	7	1	1 3/4"	44.4	7/8"	22	3/8"	12.7	3/8"	9.6	4024A	40A24GC	D40	223.40	16.00	4.231"	107	1 1/8"	29	2"	51	2 29/32"	74	3 1/4"	82.55
OSDC-256D	5 1/2"	2.47	75	11	2	1 3/4"	44.4	7/8"	22	3/8"	12.7	3/8"	9.6	4024A	40A24GC	D40	241.40	16.00	4.231"	107	1 1/8"	29	2"	51	2 29/32"	74	3 1/4"	82.55
OSDC-337	9 1/2"	4.30	100	14	1	2 1/4"	60	1"	25	1/2"	12.7	1/2"	12.7	4027A	40A27GC	D40	246.40	16.00	4.767"	121	1 1/8"	29	2 1/8"	54	3 3/32"	77	3 3/4"	95
OSDC-337D	9 1/2"	4.30	175	24	2	2 1/4"	60	1"	25	1/2"	12.7	1/2"	12.7	4027A	40A27GC	D40	266.40	16.00	4.767"	121	1 1/8"	29	2 1/8"	54	3 3/32"	77	3 3/4"	95
OSDC-362	10	3.85	120	17	1	2 1/2"	63.5	1 1/8"	28	1/2"	12.7	1/2"	12.7	4028A	40A28GC	D40	302.00	20.00	4.866"	124	1 1/8"	29	2 1/8"	54	3 3/32"	77	4"	101.6
OSDC-362D	10	3.85	185	26	2	2 1/2"	63.5	1 1/8"	28	1/2"	12.7	1/2"	12.7	4028A	40A28GC	D40	326.00	20.00	4.866"	124	1 1/8"	29	2 1/8"	54	3 3/32"	77	4"	101.6
OSDC-450	16	7.30	190	26	1	3"	80	1 3/8"	35	3/4"	19.1	3/4"	19.1	5026A	50A26GC	D50	329.60	20.00	5.775"	147	1 1/2"	38	2 7/8"	73	4 3/16"	106	4 1/2"	114
OSDC-450D	16	7.30	285	39	2	3"	80	1 3/8"	35	3/4"	19.1	3/4"	19.1	5026A	50A26GC	D50	357.60	20.00	5.775"	147	1 1/2"	38	2 7/8"	73	4 3/16"	106	4 1/2"	114
OSDC-493	17 1/2"	7.87	210	29	1	3 1/4"	82.6	1 5/8"	42	3/4"	19.1	3/4"	19.1	5028A	50A28GC	D50	493.80	22.00	6.172"	157	1 1/2"	38	2 7/8"	73	4 3/16"	106	4 7/8"	124
OSDC-493D	17 1/2"	7.87	360	50	2	3 1/4"	82.6	1 5/8"	42	3/4"	19.1	3/4"	19.1	5028A	50A28GC	D50	523.00	22.00	6.172"	157	1 1/2"	38	2 7/8"	73	4 3/16"	106	4 7/8"	124
OSDC-600	33	13.60	320	44	1	4"	100	1 3/4"	44	1"	25.4	1"	25.4	6031A	60A31GC	D60	598.00	22.00	8.093"	206	2"	51	3"	76	4 7/8"	124	6 1/2"	165
OSDC-600D	33	13.60	440	61	2	4"	100	1 3/4"	44	1"	25.4	1"	25.4	6031A	60A31GC	D60	628.00	22.00	8.093"	206	2"	51	3"	76	4 7/8"	124	6 1/2"	165
OSDC-750	60	20.30	550	76	1	5"	128	2 1/2"	64	1"	25.4	1"	25.4	8027A	80A27GC	D80	880.00	26.00	9.489"	242	2 3/8"	60	3 3/4"	95	5 29/32"	150	7 9/16"	192
OSDC-750D	60	20.30	775	107	2	5"	128	2 1/2"	64	1"	25.4	1"	25.4	8027A	80A27GC	D80	912.00	26.00	9.489"	242	2 3/8"	60	3 3/4"	95	5 29/32"	150	7 9/16"	192
OSDC-900	82	31.80	1000	139	1	5 1/2"	140	3 1/2"	90	1 1/4"	31.8	1 1/4"	31.8	8032A	80A32GC	D80	1520.00	52.00	11.000"	282	3 3/8"	93	4 1/4"	108	7 1/4"	184	8"	203
OSDC-900D	82	31.80	1250	173	2	5 1/2"	140	3 1/2"	90	1 1/4"	31.8	1 1/4"	31.8	8032A	80A32GC	D80	1584.00	52.00	11.000"	282	3 3/8"	93	4 1/4"	108	7 1/4"	184	8"	203

\*For maximum bore on OSD225, OSD225D, a shallow keyway is used of 1/2 standard depth. Use the next larger size "OSD" unit when a standard keyway is desired.

In furnishing a coupling half to be used in the "OSDC", care must be taken that a standard cut tooth sprocket is not used. The teeth of the "OSDC" coupling half are cut with special tooth form to compensate for shaft misalignment.

### FORMULA FOR TORQUE-HORSEPOWER (Foot Pounds)

$$\text{TORQUE (Ft. Lbs.)} = \frac{\text{HP} \times 5252}{\text{RPM}}$$

$$\text{HORSEPOWER} = \frac{\text{Torque} \times \text{RPM}}{5252}$$



**IMPORTANT NOTE:** The chart shown above is for stock sizes. The "OSDC" overload safety device can be made to suit your application. Send us your blueprints or specifications for recommendations by our engineering department.

### "OSDC" PARTS LIST

	OSDC-131	OSDC-225	OSDC-256	OSDC-337	OSDC-362	OSDC-450	OSDC-493	OSDC-600	OSDC-750	OSDC-900
OSDC COUPLING HALF	62.00	64.80	80.00	95.00	110.50	126.00	213.50	271.00	380.00	452.00
OSDC COUPLING CHAIN	22.50	23.70	28.00	32.00	36.80	46.60	75.60	105.00	186.50	202.00
OSD SPROCKET	33.00	44.80	49.80	52.00	58.00	64.00	82.50	101.00	128.00	153.50

FOR PARTS OF OSD HALF, SEE PAGE 5

# MODEL "ROSDC" RIGID OVERLOAD SAFETY DEVICE COUPLING

The Dalton ROSDC (Rigid Overload Safety Device Coupling) provides overload protection through the use of an OSD unit combined with a rigid coupling half counterbored to fit the OSD flange. All-steel rigid coupling half is bolted to a basic OSD unit to form a rigid coupling with the overload feature.

The ROSDC can be set with a torque wrench for maximum load desired. The unit functions as a rigid coupling until an overload occurs, causing the ROSDC to dis-engage. The device is automatically re-engaged when the overload is eliminated.

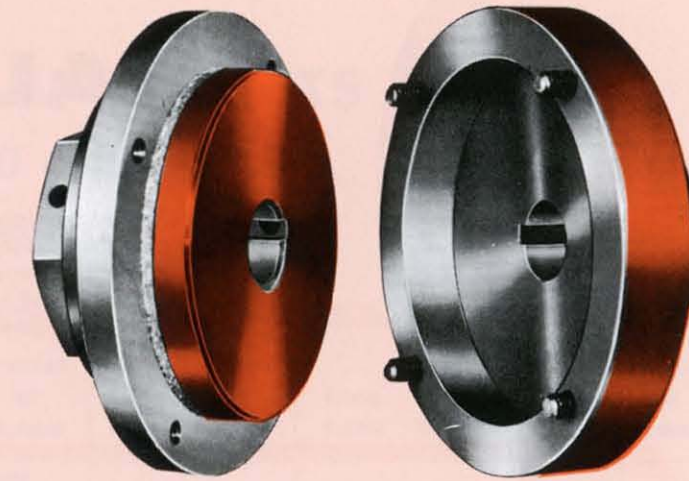
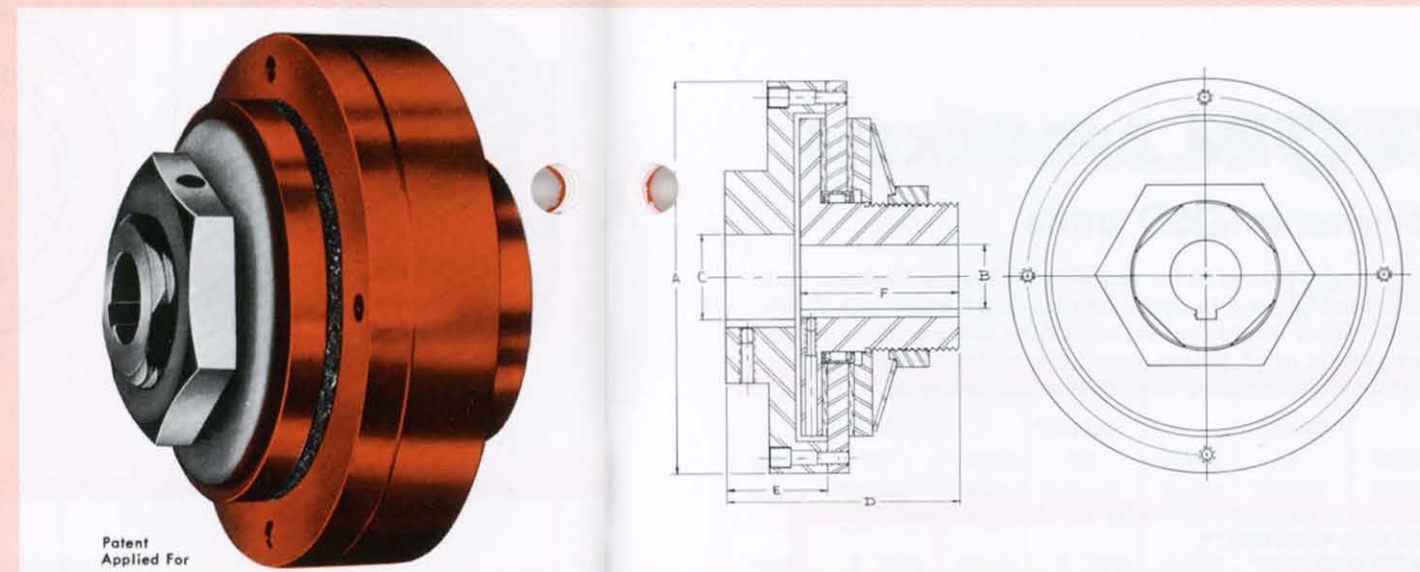

Rigid Coupling No.	Weight		Max. Torque		No. Springs	A O.D.		Minimum Bore				Maximum Bore				D Overall Length Thru Bore		E Length Thru Coupling		F Length Thru OSD		Finished Bore, KW & SS In Rigid Coupling Halves (See Page 5 for Finished Bore in OSD Halves)	Price	For Bore Sizes Not Shown, Add Charges to This List Per Half	Rigid Coupling No.
	Lbs.	kg	Ft. Lbs.	mkp		In.	mm	B OSD Half		C Rigid Coupling Half		B OSD Half		C Rigid Coupling Half		In.	mm	In.	mm	In.	mm				
								In.	mm	In.	mm	In.	mm	In.	mm										
ROSDC-131	2	.90	6	1	1	2"	51	1/4"	6.4	1/4"	6.4	3/8"	10	3/4"	20	2 1/16"	62	1 3/8"	35	1 3/8"	35	1/4", 5/16", 3/8"	\$ 172.00	\$ 16.00	ROSDC-131
ROSDC-131D	2	.90	10	2	2	2"	51	1/4"	6.4	1/4"	6.4	3/8"	10	3/4"	20	2 1/16"	62	1 3/8"	35	1 3/8"	35	1/4", 5/16", 3/8"	182.00	16.00	ROSDC-131D
ROSDC-225	5	2.30	35	5	1	3 1/2"	89	3/8"	9.6	3/8"	9.6	3/4"	19	1 1/4"	32	3"	76	1 1/2"	38	2"	51	3/8", 1/2", 5/8", 3/4"	200.00	16.00	ROSDC-225
ROSDC-225D	5	2.30	50	7	2	3 1/2"	89	3/8"	9.6	3/8"	9.6	3/4"	19	1 1/4"	32	3"	76	1 1/2"	38	2"	51	3/8", 1/2", 5/8", 3/4"	216.00	16.00	ROSDC-225D
ROSDC-256	5 1/2	2.47	50	7	1	4"	101.6	3/8"	9.6	1/2"	12.7	7/8"	22	1 1/2"	38	3"	76	1 1/2"	38	2"	51	3/8", 1/2", 5/8", 3/4", 7/8", 1"	250.00	16.00	ROSDC-256
ROSDC-256D	5 1/2	2.47	75	11	2	4"	101.6	3/8"	9.6	1/2"	12.7	7/8"	22	1 1/2"	38	3"	76	1 1/2"	38	2"	51	3/8", 1/2", 5/8", 3/4", 7/8", 1"	268.00	16.00	ROSDC-256D
ROSDC-337	12	5.50	100	14	1	4 1/2"	114	1/2"	12.7	1/2"	12.7	1"	25	1 3/4"	45	3 3/8"	86	1 3/4"	45	2 1/8"	54	1/2", 5/8", 3/4", 7/8", 1"	300.00	16.00	ROSDC-337
ROSDC-337D	12	5.50	175	24	2	4 1/2"	114	1/2"	12.7	1/2"	12.7	1"	25	1 3/4"	45	3 3/8"	86	1 3/4"	45	2 1/8"	54	1/2", 5/8", 3/4", 7/8", 1"	320.00	16.00	ROSDC-337D
ROSDC-362	12 1/2	4.28	120	17	1	4 7/8"	124	1/2"	12.7	1/2"	12.7	1 1/8"	28	2"	51	3 3/8"	86	1 3/4"	45	2 1/8"	54	1/2", 5/8", 3/4", 1", 1 1/8", 1 1/4"	367.00	20.00	ROSDC-362
ROSDC-362D	12 1/2	4.28	185	26	2	4 7/8"	124	1/2"	12.7	1/2"	12.7	1 1/8"	28	2"	51	3 3/8"	86	1 3/4"	45	2 1/8"	54	1/2", 5/8", 3/4", 1", 1 1/8", 1 1/4"	391.00	20.00	ROSDC-362D
ROSDC-450	20	9.10	190	26	1	6"	153	3/4"	19.1	3/4"	19.1	1 3/8"	35	2 1/4"	58	4 3/8"	111	2"	51	2 7/8"	73	3/4", 1", 1 1/8", 1 1/4"	434.00	20.00	ROSDC-450
ROSDC-450D	20	9.10	285	39	2	6"	153	3/4"	19.1	3/4"	19.1	1 3/8"	35	2 1/4"	58	4 3/8"	111	2"	51	2 7/8"	73	3/4", 1", 1 1/8", 1 1/4"	462.00	20.00	ROSDC-450D
ROSDC-493	20 1/2	8.10	210	29	1	6 1/4"	158.75	3/4"	19.1	3/4"	19.1	1 5/8"	42	2 1/2"	64	4 3/8"	111	2"	51	2 7/8"	73	3/4", 1", 1 1/4", 1 1/2", 1 3/4"	575.00	22.00	ROSDC-493
ROSDC-493D	20 1/2	8.10	360	50	2	6 1/4"	158.75	3/4"	19.1	3/4"	19.1	1 5/8"	42	2 1/2"	64	4 3/8"	111	2"	51	2 7/8"	73	3/4", 1", 1 1/4", 1 1/2", 1 3/4"	604.00	22.00	ROSDC-493D
ROSDC-600	38	17.30	320	44	1	7 3/4"	197	1"	25.4	1"	25.4	1 3/4"	44	2 3/4"	70	4 3/4"	120	2 3/8"	60	3"	76	1", 1 1/4", 1 3/8", 1 1/2"	716.00	22.00	ROSDC-600
ROSDC-600D	38	17.30	440	61	2	7 3/4"	197	1"	25.4	1"	25.4	1 3/4"	44	2 3/4"	70	4 3/4"	120	2 3/8"	60	3"	76	1", 1 1/4", 1 3/8", 1 1/2"	746.00	22.00	ROSDC-600D
ROSDC-750	60	27.20	550	76	1	9 1/4"	235	1"	25.4	1"	25.4	2 1/2"	64	3 1/2"	90	5 1/2"	140	2 3/8"	60	3 3/4"	95	1", 1 1/4", 1 1/2", 1 3/4", 2", 2 1/4"	1184.00	26.00	ROSDC-750
ROSDC-750D	60	27.20	775	107	2	9 1/4"	235	1"	25.4	1"	25.4	2 1/2"	64	3 1/2"	90	5 1/2"	140	2 3/8"	60	3 3/4"	95	1", 1 1/4", 1 1/2", 1 3/4", 2", 2 1/4"	1216.00	26.00	ROSDC-750D
ROSDC-900	85	38.60	1000	139	1	11"	280	1 1/4"	31.8	1 1/4"	31.8	3 1/2"	90	4 1/4"	110	6 1/2"	165	3"	76	4 1/4"	108	1 1/4", 1 1/2", 1 3/4", 2 1/4", 2 1/2"	1840.00	52.00	ROSDC-900
ROSDC-900D	85	38.60	1250	173	2	11"	280	1 1/4"	31.8	1 1/4"	31.8	3 1/2"	90	4 1/4"	110	6 1/2"	165	3"	76	4 1/4"	108	1 1/4", 1 1/2", 1 3/4", 2 1/4", 2 1/2"	1904.00	52.00	ROSDC-900D

### IMPORTANT NOTE:

The chart shown above is for stock sizes. The "ROSDC" overload safety device can be made to suit your application. Send us your blueprints or specifications for recommendations by our engineering department.

### "ROSDC" PARTS LIST

	ROSDC 131	ROSDC 225	ROSDC 256	ROSDC 337	ROSDC 362	ROSDC 450	ROSDC 493	ROSDC 600	ROSDC 750	ROSDC 900
ROSDC COUPLING HALF	80.00	88.50	111.00	132.50	172.00	210.00	284.00	357.00	630.00	690.00
ROSDC PLATE	53.00	55.50	71.60	88.00	110.00	130.60	178.50	226.60	412.00	464.00
ROSDC CAPSCREWS (SET)	26.50	26.50	28.00	29.30	32.00	34.60	42.50	50.50	59.00	74.00

FOR PARTS OF OSD HALF, SEE PAGE 5



# DALTON SPROCKETS

for use in OSD units

Specially ground sprockets are recommended for use with all Torque Limiters. Both faces of Dalton OSD sprockets are ground to approximately a 32 micro-inch finish. Uniform surfaces and parallel faces insure that Dalton OSD's will maintain proper torque release and re-engagement much longer than units without special sprockets. In addition, fibers last longer and OSD's require less maintenance.

## MINIMUM SIZE SPROCKETS TO FIT OSD UNIT

OSD-131	OSD-225	OSD-256	OSD-337	OSD-362	OSD-450	OSD-493	OSD-600	OSD-750	OSD-900
25A20G	25A32G	35A25G	35A31G	35A34G	35A41G*	41A35G*	41A42G*	40A52G*	60A41G*
35A14G	35A22G	41A20G	41A25G	41A26G	41A32G	40A35G*	40A42G*	50A42G*	80A32G
41A12G	41A18G	40A20G	40A25G	40A26G	40A32G	50A28G*	50A34G	60A35G*	100A26G
40A12G	40A18G	50A17G	50A21G	50A22G	50A26G	60A24G	60A30G	80A27G	120A22G
50A10G	50A15G	60A15G	60A18G	60A19G	60A23G	80A19G	80A22G	100A22G	140A20G
	60A13G		80A14G	80A15G	80A18G	100A16G	100A19G	120A19G	160A18G
					100A15G	120A14G	120A17G	140A17G	
					120A13G		140A15G	160A15G	
							160A14G		

\*3 fibers must be used

## BORE TOLERANCES FOR SPROCKETS USED IN OSD UNITS

OSD-131		OSD-256		OSD-362		OSD-493		OSD-750	
In.	mm	In.	mm	In.	mm	In.	mm	In.	mm
.8120	20.6248	1.4995	38.0873	1.9995	50.7873	2.6245	66.6623	3.9995	101.538
.8130	20.6502	1.5005	38.1127	2.0005	50.8127	2.6255	66.6877	4.0005	101.662

OSD-225		OSD-337		OSD-450		OSD-600		OSD-900	
In.	mm	In.	mm	In.	mm	In.	mm	In.	mm
1.2495	31.7375	1.8745	49.6125	2.2495	57.1375	2.8795	73.1395	4.9995	126.938
1.2505	31.7625	1.8755	49.6375	2.2505	57.1625	2.8805	73.1645	5.0005	127.062

# DALTON MODEL "DRC" STEEL RIGID COUPLINGS

The Dalton "DRC" RIGID COUPLING is designed for speeds up to 3600 RPM. The shaft size determines the coupling to be used. Extreme care for perfect alignment must be exercised.

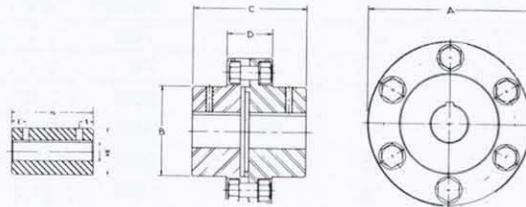

Rigid Coupling No.	Weight Lbs.	Minimum Bore	Maximum Bore	DESCRIPTION				Bolt Size	No. Bolts	LIST PRICES	
				A	B	C	D			Min. Bore No KW or SS	Add to List for Finish Bore with KW or SS
DRC25	4½	½"	1"	2½	—	4½	—	None	None	46.00	24.00
DRC35	5	½"	1¼"	3½	2	3	1½	⅜-18 1" Long	4	144.00	48.00
DRC45	8	¾"	1¾"	4½	3	3	1½	⅜-18 1" Long	4	197.00	48.00
DRC60	16	1"	2¼"	6	4	3½	1½	⅜-16 1" Long	5	256.00	56.00
DRC67	27	1¼"	2¾"	6¾	4¾	3¾	1¾	⅜-16 1¼" Long	5	302.00	72.00
DRC75	33	1½"	3½"	7½	5½	4	1¾	⅜-16 1¼" Long	6	334.00	80.00
DRC85	49	1¾"	4"	8½	6	4½	2	½-13 1½" Long	6	414.00	96.00
DRC100	68	2"	5"	10	7½	5	2	½-13 1½" Long	8	740.00	120.00

# DALTON SPROCKETS

for use in OSD units

## LIST PRICES

Catalog Number	*Price Each Not Hardened	Catalog Number	*Price Each Not Hardened	Catalog Number	*Price Each Not Hardened	Catalog Number	*Price Each Not Hardened	Catalog Number	*Price Each Not Hardened	Catalog Number	*Price Each Not Hardened	Catalog Number	*Price Each Not Hardened
25A20G	\$ 31.20	40A17G	\$ 28.80	41A22G	\$ 35.20	50A30G	\$ 54.40	60A35G	\$ 82.40	100A12G	\$ 67.20	120A24G	\$ 297.60
25A21G	33.60	40A18G	30.40	41A23G	36.00	50A32G	57.60	60A36G	84.80	100A13G	70.40	120A26G	336.00
25A22G	35.20	40A19G	32.00	41A24G	36.80	50A34G	60.80	60A38G	89.60	100A14G	73.60	120A30G	388.80
25A24G	38.40	40A20G	33.60	41A25G	37.60	50A35G	62.40	60A40G	94.40	100A15G	77.60	120A32G	442.40
25A25G	39.20	40A21G	34.40	41A26G	38.40	50A36G	64.00	60A42G	100.00	100A16G	83.20	120A36G	528.00
25A26G	43.20	40A22G	35.20	41A27G	39.20	50A38G	67.20	60A45G	106.40	100A17G	89.60	120A40G	618.40
25A28G	46.40	40A23G	36.00	41A28G	40.00	50A40G	70.40	60A48G	116.80	100A18G	96.00	120A45G	752.00
25A30G	48.00	40A24G	36.80	41A29G	41.60	50A42G	73.60	60A54G	140.80	100A19G	104.80	120A48G	840.00
25A32G	52.00	40A25G	37.60	41A30G	43.20	50A45G	76.80	60A60G	174.40	100A20G	113.60	120A60G	1184.00
		40A26G	38.40	41A32G	44.80	50A48G	81.60	60A72G	241.60	100A21G	122.40		
35A14G	22.40											140A15G	221.60
35A15G	23.20	40A27G	39.20	41A36G	47.20	50A54G	94.40	60A80G	315.20	100A22G	131.20	140A16G	236.80
35A16G	24.00	40A28G	40.00	41A40G	49.60	50A60G	108.80			100A23G	141.60	140A17G	252.00
35A17G	24.80	40A29G	41.60	41A42G	52.00	50A72G	142.40	80A14G	49.60	100A24G	152.00	140A18G	268.00
35A18G	25.60	40A30G	43.20	41A45G	54.40	50A80G	185.60	80A18G	60.80	100A26G	172.80	140A19G	288.00
		40A32G	44.80	41A48G	57.60	50A84G	208.00	80A19G	64.00	100A28G	193.60		
35A19G	26.40							80A20G	68.00			140A20G	306.40
35A20G	27.20	40A34G	46.40	41A54G	62.40	50A96G	256.00	80A21G	72.00	100A30G	212.00	140A21G	323.20
35A21G	28.00	40A35G	48.00	41A60G	70.40			80A22G	76.00	100A32G	230.40	140A24G	395.20
35A22G	28.80	40A36G	49.60	41A72G	86.40	60A13G	36.80			100A35G	280.00	140A27G	444.80
35A23G	29.60	40A38G	51.20	41A84G	115.20	60A14G	38.40	80A23G	80.00	100A36G	292.80	140A30G	548.00
		40A40G	52.80			60A15G	40.00	80A24G	84.00	100A38G	323.20		
35A24G	30.40			50A10G	32.80	60A16G	42.40	80A25G	88.00			140A36G	683.20
35A25G	31.20	40A42G	56.00	50A11G	33.60	60A17G	44.80	80A26G	92.00	100A40G	364.80	140A40G	864.00
35A26G	32.00	40A45G	59.20	50A12G	34.40			80A27G	96.00	100A42G	398.40	140A45G	1024.00
35A28G	32.80	40A48G	62.40	50A13G	34.80	60A18G	47.20			100A45G	454.40		
35A30G	33.60	40A54G	70.40	50A14G	35.20	60A19G	49.60	80A28G	100.00	100A48G	503.20	160A14G	291.20
		40A60G	80.00			60A20G	52.00	80A29G	104.00	100A54G	597.60	160A15G	315.20
35A32G	35.20			50A15G	36.00	60A21G	53.60	80A30G	108.00			160A16G	339.20
35A36G	36.80	40A72G	97.60	50A16G	36.80	60A22G	56.00	80A32G	115.20	100A60G	707.20	160A17G	360.00
35A40G	38.40	40A84G	129.60	50A17G	37.60			80A34G	126.40	100A72G	912.00	160A18G	384.00
35A42G	40.00	40A96G	177.60	50A18G	38.40	60A23G	57.60						
				50A19G	39.20	60A24G	59.20	80A35G	132.00	120A13G	163.20	160A19G	404.80
35A45G	41.60	41A12G	24.00			60A25G	60.80	80A36G	137.60	120A14G	172.80	160A20G	430.40
35A48G	43.20	41A13G	24.80	50A20G	40.00	60A26G	62.40	80A38G	150.40	120A15G	185.60	160A21G	448.00
35A54G	46.40	41A14G	25.20	50A21G	41.60	60A27G	64.00	80A40G	162.40	120A16G	193.60	160A22G	470.40
35A60G	51.20	41A15G	25.60	50A22G	43.20			80A42G	180.00	120A17G	205.60	160A24G	557.60
35A72G	60.00	41A16G	27.20	50A23G	44.80	60A28G	66.40						
				50A24G	46.40	60A29G	68.80	80A45G	206.40	120A18G	218.40	160A27G	636.80
35A84G	70.40	41A17G	28.80			60A30G	72.00	80A48G	235.20	120A19G	230.40	160A30G	790.40
		41A18G	30.40	50A25G	47.20	60A32G	76.00	80A54G	289.60	120A20G	243.20	160A36G	1065.60
40A12G	24.00	41A19G	32.00	50A26G	48.00	60A34G	80.00	80A60G	363.20	120A21G	256.00	160A45G	1536.00
40A13G	24.80	41A20G	33.60	50A27G	49.60			80A72G	473.60	120A22G	268.80		
40A14G	25.20	41A21G	34.40	50A28G	51.20								
40A15G	25.60			50A29G	52.80								
40A16G	27.20												



# DALTON

## ROLLER CHAIN SHEAR PIN COUPLING "RCSPC"

A complete line of Dalton Shear Pin (torque limiter) Roller Chain Couplings was developed for applications where horsepower and torque are high or extreme accuracy is desired for torque settings.

The coupling halves are hobbled with a special tooth form and hardened 45 to 50 Rockwell "C." Roller chain couplings when used correctly are unsurpassed by any other more expensive coupling. Standard sprockets should not be used for coupling applications.

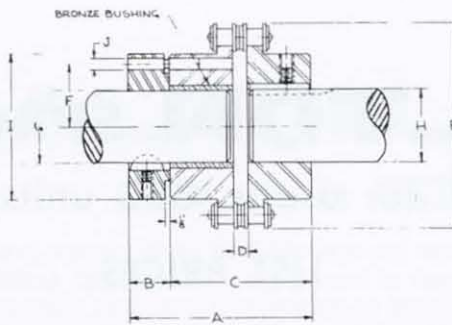

Shear Pin Coupling Size	A	B	C	D	E	F	Max G	Max H	I	J	Stock Bores Shear Pin Cplg Half	Stock Bores St'd Cplg Half Includes KW & SS	Coupling Complete	Coupling Chain Only	Shear Pin Coupling Half	Standard Coupling Half	Shear Pin Collar	Shear Pins (3 Identical Pins)
SP5016	3 5/8	3/4	2 7/8	3/8	3 25/32	1"	1 1/4	1 5/8	2 1/8	5/16	3/8, 1/2, 1, 1 1/8, 1 1/2, 1 3/4	3/8, 1/2, 1, 1 1/8, 1 1/2, 1 3/4, 1 5/8, 1 3/4	163.00	23.18	48.80	49.20	27.80	24.00
SP5018	3 5/8	3/4	2 7/8	3/8	4 3/16	1 3/4	1 5/8	1 5/8	3 3/4	3/8	3/4, 1/2, 1, 1 1/8, 1 1/2, 1 3/4, 1 5/8, 1 3/4	3/4, 1 1/4, 1 1/2, 1 3/4, 1 5/8, 1 3/4, 1 5/8, 1 3/4	193.00	25.78	63.00	54.70	31.60	29.00
SP6018	4 5/16	7/8	3 7/16	7/16	5	1 1/2	1 7/8	2 3/8	4	7/16	1, 1 1/4, 1 1/2, 1 3/4, 1 5/8, 1 3/4, 1 7/8	1, 1 1/4, 1 1/2, 1 3/4, 1 5/8, 1 3/4, 1 5/8, 2, 2 1/4, 2 1/2	276.00	46.40	101.60	77.50	34.00	32.00
SP6020	4 5/16	7/8	3 7/16	7/16	5 1/2	1 5/8	2 1/8	2 5/8	4 1/4	1/2	1 1/2, 1 1/4, 1 1/2, 1 3/4, 1 5/8, 1 3/4, 1 5/8	1 1/2, 1 1/4, 1 1/2, 1 3/4, 1 5/8, 1 3/4, 1 5/8, 2 1/4, 2 1/2, 2 3/4, 2 5/8	322.00	51.36	125.60	86.00	42.00	35.00
SP8018	5 27/64	1	4 27/64	27/64	6 11/16	2"	2 1/2	3	5	1/2	1 1/2, 1 3/4, 1 5/8, 1 3/4, 1 5/8, 2, 2 1/4, 2 1/2, 2 3/4, 2 5/8	1 1/2, 1 1/4, 1 1/2, 1 3/4, 1 5/8, 1 3/4, 1 5/8, 2, 2 1/4, 2 1/2, 2 3/4, 2 5/8, 2 7/8	495.00	107.36	181.00	155.60	47.80	36.96
SP8020	5 27/64	1	4 27/64	27/64	7 5/16	2 1/4	3	3 1/2	5 1/2	5/16	1 1/2, 1 3/4, 1 5/8, 1 3/4, 1 5/8, 2, 2 1/4, 2 1/2, 2 3/4, 2 5/8, 2 7/8	1 1/2, 1 1/4, 1 1/2, 1 3/4, 1 5/8, 1 3/4, 1 5/8, 2, 2 1/4, 2 1/2, 2 3/4, 2 5/8, 2 7/8	644.00	116.52	274.08	181.00	71.04	38.40
SP10018	6 23/32	1	5 23/32	23/32	8 11/32	2 3/4	3 1/4	3 7/8	6 1/4	9/16	1 1/2, 1 3/4, 1 5/8, 1 3/4, 1 5/8, 2, 2 1/4, 2 1/2, 2 3/4, 2 5/8	1 1/2, 1 1/4, 1 1/2, 1 3/4, 1 5/8, 1 3/4, 1 5/8, 2, 2 1/4, 2 1/2, 2 3/4, 2 5/8, 2 7/8	1020.00	190.80	418.32	356.00	88.80	38.40
SP10020	6 23/32	1	5 23/32	23/32	9 1/8	2 7/8	3 3/4	4 3/8	7	3/8	2, 2 1/4, 2 1/2, 2 3/4, 2 5/8, 2 7/8, 3	2, 2 1/4, 2 1/2, 2 3/4, 2 5/8, 2 7/8, 3	1170.00	211.20	478.80	396.00	117.60	47.52
SP12020	7 1/8	1 1/8	6	1	10 15/16	3 1/2	4 1/2	5	8 1/4	3/8	2, 2 1/4, 2 1/2, 2 3/4, 2 5/8, 2 7/8, 3, 3 1/4, 3 1/2, 3 3/4, 4	2, 2 1/4, 2 1/2, 2 3/4, 2 5/8, 2 7/8, 3, 3 1/4, 3 1/2, 3 3/4, 4	1810.00	298.56	765.36	656.00	166.80	54.00

The Dalton Roller Chain Shear Coupling (RCSPC) has an accurate torque release obtained by precision machining of the shear pin neck diameter and material used.

The maximum capacity in inch pounds is up to five times greater than the rated capacity of friction type torque limiters.

When loads occur beyond the rated capacity, the pin shears at the neck. A new pin when installed allows operation of the equipment with no damage to any part, mechanical or otherwise. The pin must be replaced with a Dalton Shear Pin or equivalent as shown in the catalog.

Maximum capacities range from 738 inch pounds to 66,504 inch pounds.

Gear Shear Pin Couplings (GSPC) are available to order.

Our engineering department is available for more information or when stock sizes do not suit your needs.

Pricing Formula: Machining List X Multiplier +  $\frac{\text{Net Set-Up}}{\text{Quantity Identical Cplg. Halves}}$  = Reworking Charge (Net Each)

Catalog No.	SP5016 & SP5018	SP6018 & SP6020	SP8018 & SP8020	SP10018 & SP10020	SP12020
Machining List — St'd. Cplng Half	\$ 8.40	\$ 14.40	\$ 14.40	\$ 25.00	\$ 32.00
Machining *List — Shear Pin Cplng Half	12.60	21.60	21.60	37.50	48.00
Net Set Up	25.00	25.00	25.00	25.00	25.00

Reworking charge for each half non-St'd bore, KW&SS (no reduction for omitting any of these features)

\*Includes reboring, KW&SS in collar, reboring shear pin coupling half.

The following table gives the torque carrying capacity of shear pins.

It is based on the following formula:

TT=ARS#N=0.7854D<sup>2</sup>S#NR when

T= Allowable torque in inch pounds.

R=Radius from center of shaft to center of pin in inches.

A= Area at notch of shear pin in square inches.

D=Diameter at notch of shear pin in inches.

N=Number of pins in shear. The tables are given for 1 pin.

S#=Shearing stress of shear pins in pounds per square inch.

### STEEL SHEAR PINS (ULTIMATE SHEAR STRESS 62,000 PSI) ALLOWABLE TORQUE ON ONE PIN IN INCH-POUNDS

Coupling Size	NECK DIAMETER OF PIN IN INCHES							
	1/8	3/16	1/4	5/16	3/8	7/16	1/2	5/8
SP5016	738	1688	3006					
SP5018	923	2103	3769	5901				
SP6018	1114	2523	4529	7101	10,249			
SP6020	1207	2739	4911	7684	11,087	15,101		
SP8018	1493	3386	6039	9473	13,647	18,599		
SP8020	1686	3814	6809	10,654	15,372	20,924	27,362	
SP10018		4235	7582	11,829	17,084	23,267	30,396	
SP10020			8706	13,621	19,561	26,686	34,887	54,500
SP12020				16,582	23,900	32,586	42,556	66,504

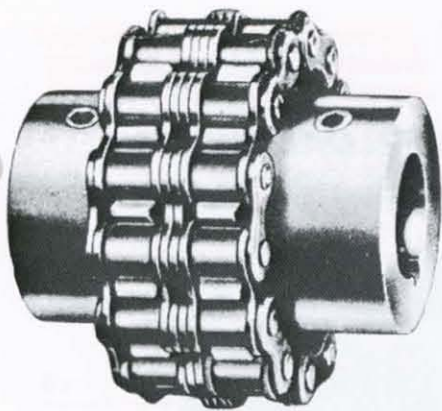

# DALTON FLEXIBLE COUPLINGS

DIMENSIONS IN INCHES AND LIST PRICES

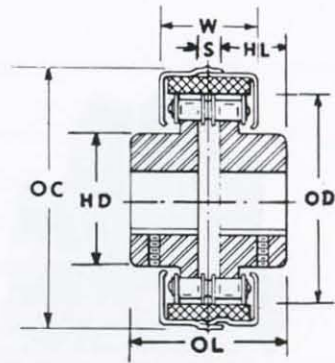

## FLEXIBLE COUPLINGS WITH FIXED BORES

Coupling Number	Coupling Chain Only List Price	Coupling Half Only List Price	H.D. Inches	H.L. Inches	S. Inches	O.L. Inches	O.D. Inches	Approx. Weight Lbs.	Stock Bores — Inches Includes Standard Keyway and Setscrew
4012AC	\$ 11.00	\$ 24.80	1 13/32	1 1/8	9/32	2 13/32	2 13/32	1.3	7/16, 1/2, 5/8, 3/4
4016AC	14.00	29.40	1 31/32	1 1/8	9/32	2 13/32	3 1/32	2.5	3/8, 1/2, 5/8, 3/4, 1 1/16, 1 1/8, 1 1/4
5016AC	20.60	39.40	2 1/2	1 1/4	3/8	2 7/8	3 23/32	5.0	3/4, 1 1/8, 1 1/4, 1 1/2, 1 5/8, 1 3/4, 1 7/8, 1 15/16
5018AC	22.80	43.80	2 23/32	1 1/4	3/8	2 7/8	4 1/16	7.3	3/4, 1 1/4, 1 1/2, 1 5/8, 1 3/4, 1 7/8, 1 15/16, 1 3/4
6018AC	41.20	62.00	3 1/2	1 1/2	7/16	3 1/16	5	10.5	1, 1 1/16, 1 1/2, 1 5/8, 1 3/4, 1 7/8, 1 15/16, 2, 2 1/8, 2 1/4
6020AC	45.60	68.80	3 7/8	1 1/2	7/16	3 1/16	5 1/2	16.5	1 1/8, 1 1/4, 1 15/16, 2 1/8, 2 1/16, 2 3/8, 2 5/8
8018AC	82.60	124.60	4 9/16	2	3/64	4 3/64	6 1 1/16	23.0	1 1/8, 1 15/16, 2, 2 1/8, 2 1/16, 2 3/8, 2 5/8, 2 7/8, 2 15/16
8020AC	91.40	144.80	5 3/8	2	3/64	4 3/64	7 7/16	36.0	1 1/2, 2 1/16, 2 1/8, 2 1/16, 2 15/16, 3 1/8, 3 1/4, 3 1/2
10018AC	149.60	285.20	5 1 1/16	2 1/2	2 3/32	5 2 3/32	8 1 1/32	45.0	1 1/2, 2 1/16, 2 1/8, 3 1/16
10020AC	165.60	317.20	6 2 3/32	2 1/2	2 3/32	5 2 3/32	9 7/8	64.0	2, 3 3/8, 3 1/2, 3 15/16

Reworking charge for each half non-standard bore, keyway and setscrew (no reduction for omitting any of these features).

Catalog No.	4012 & 4016	5016 & 5018	6018 & 6020	8018 & 8020	10018 & 10020
Machining List Each Half	\$ 8.40	\$ 8.40	\$ 14.40	\$ 14.40	\$ 25.00
Net Set-Up	25.00	25.00	25.00	25.00	25.00

Pricing Formula: Machining List X Multiplier +  $\frac{\text{Net Set-Up}}{\text{Quantity Identical Cplg. Halves}}$  = Reworking Charge (Net Each)

## DALTON BALL BEARING IDLER SPROCKETS

- PRECISION SEALED BALL BEARINGS offer superior performance
- SUPPLIED WITH HARDENED OR UNHARDENED TEETH in convenient bore sizes.

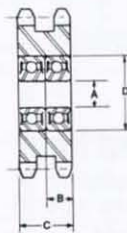

DOUBLE STRAND SPROCKET

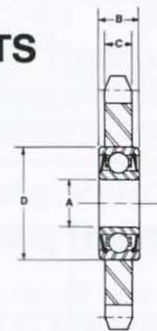

SINGLE STRAND SPROCKET

Idler No.	Sprocket Number	A.S.A. Chain Number	Pitch	No. of Teeth	A Stock Bore .0000-.0005	B Bearing Width	C Sprocket Width	D Bearing OD	Bearing Radial Load Rating @ 500 rpm	List Price Not Hardened	List Price Hardened
101	25A20	25	1/4	20	3/8	5/16	110	29/32	144	\$ 23.00	\$ 27.00
102	35A19	35	3/8	19	3/8, 1/2	3/8	168	1 1/8	251	23.75	27.50
103	41A18	41	1/2	18	1/2, 5/8	7/16	227	1 3/8	476	26.75	30.25
104	40A18	40	1/2	18	1/2, 5/8	7/16	284	1 3/8	476	26.75	30.25
105	50A17	50	5/8	17	1/2, 5/8	7/16	343	1 3/8	476	27.50	31.50
106	60A15	60	3/4	15	1/2, 5/8	7/16	459	1 3/8	476	29.00	33.25
108	80A12	80	1	12	3/4	39/64	575	1 25/32	958	44.00	49.00
202	D35A19	35-2	3/8	19	1/2, 5/8	7/16	561	1 3/8	476	70.00	74.50
204	D40A18	40-2	1/2	18	1/2, 5/8	7/16	841	1 3/8	952	92.00	96.50
205	D50A17	50-2	5/8	17	1/2, 5/8	7/16	1,045	1 3/8	952	120.00	126.00
206	D60A15	60-2	3/4	15	1/2, 5/8	7/16	1,345	1 3/8	952	140.00	148.00
208	D80A12	80-2	1	12	3/4	39/64	1,710	1 25/32	1916	170.00	179.00

\*2 bearings per unit

SPECIFY BORE SIZE AND IF HARDENED

Sprockets in idlers #101 and #102 have ground faces to insure quality

IN ADDITION TO THESE STOCK SIZES, SPECIAL SIZES CAN BE FURNISHED

## SAFETY OVERLOAD SWITCH

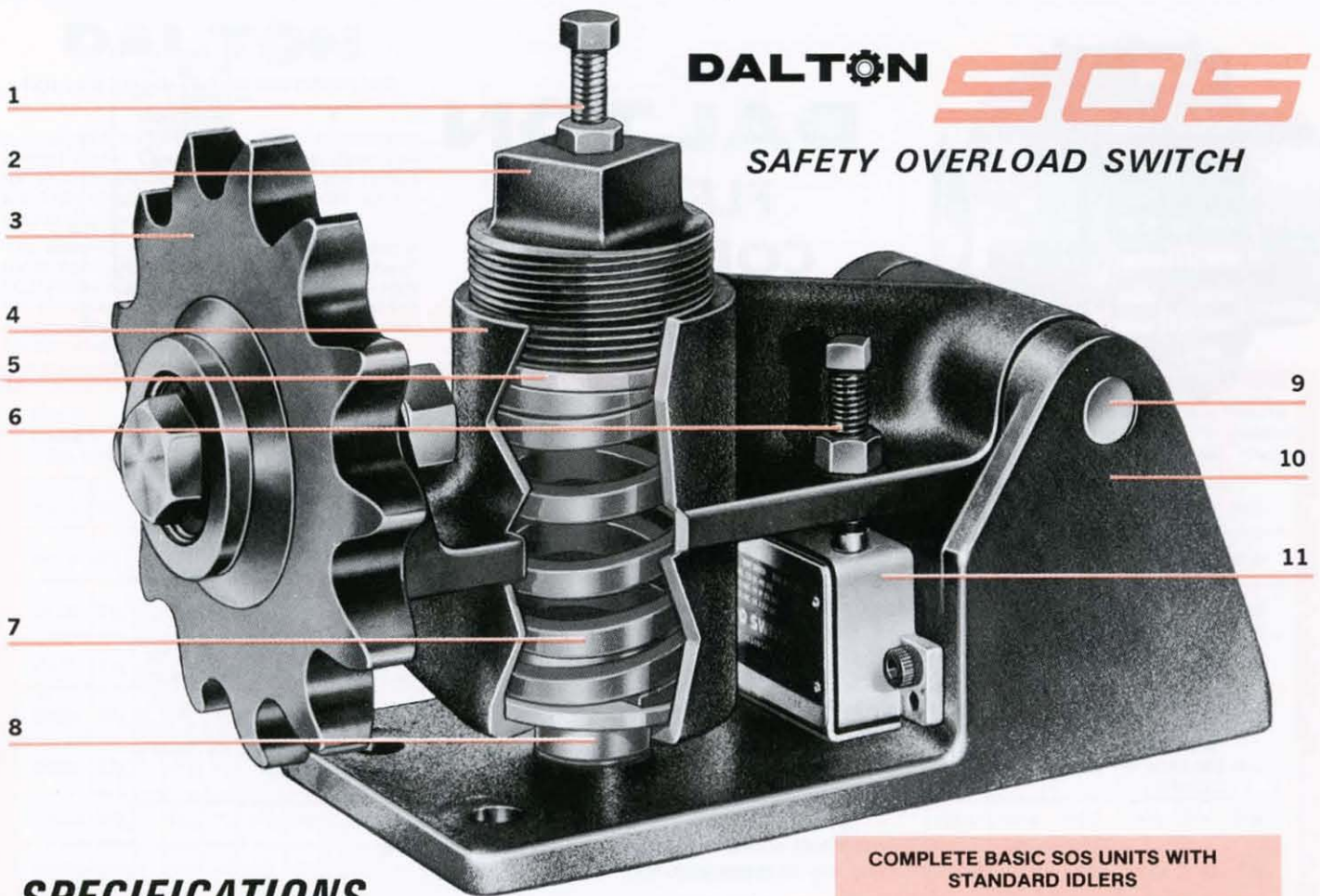

### SPECIFICATIONS

1. FINAL SPRING TENSION ADJUSTMENT BOLT
2. MAIN NUT SPRING CONTAINER
3. SPROCKET WITH BALL BEARING IDLER SHAFT
4. CAST DUCTILE SPRING HOUSING AND IDLER ARM
5. UPPER ADJUSTING PLATE
6. MICRO SWITCH ADJUSTMENT BOLT
7. SENSING SPRING
8. LOWER ADJUSTING PLATE
9. FULCRUM SHAFT
10. MAIN BASE DUCTILE CASTING
11. MICRO SWITCH (NORMALLY CLOSED)

**DIMENSIONS:** OVERALL HEIGHT 8", WIDTH 4¼", LENGTH 9"

**Weight:** SOS #1 9#  
SOS #2 17#

### Turns off power source at pre-set load limit

The Dalton SOS Safety Overload Switch is designed specifically to insure against breakdowns in all types of driven machinery by providing automatic shutdown at the precise moment an overload occurs.

The proven reliable SOS Safety Overload Switch reduces downtime and production loss in medium and heavy duty chain driven systems by shutting off power before excessive torque can cause costly damage to mechanical components.

One model can accommodate chain drives of ¾-inch pitch #60 chain to 2-inch pitch #160 chain. A final spring adjustment screw permits rapid, easy pre-setting for maximum desired load regardless of chain pitch and size.

The Dalton SOS Safety Overload Switch is effective, economical insurance against heavy-duty chain drive overloads in a wide range of applications.

### COMPLETE BASIC SOS UNITS WITH STANDARD IDLERS

	LIST PRICE
35SOS-19-1 .....	\$543.40
41SOS-18-1 .....	543.60
40SOS-18-1 .....	543.60
50SOS-17-1 .....	544.80
60SOS-15-1 .....	547.20
40SOS-18-2 .....	1060.00
50SOS-17-2 .....	1064.00
60SOS-15-2 .....	1068.00
80SOS-15-2 .....	1088.00
100SOS-13-2 .....	1140.00
120SOS-13-2 .....	1240.00
140SOS-11-2 .....	1304.00
160SOS-11-2 .....	1400.00

Other sprocket sizes available. Sensing springs available in various sizes determined by application.

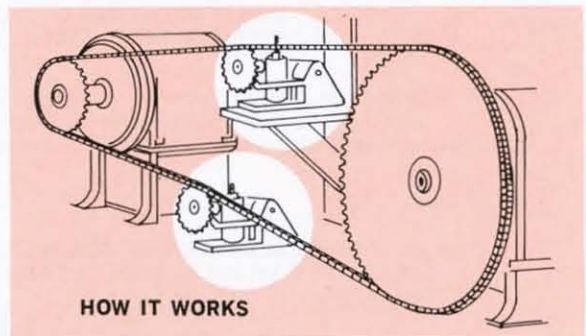

The SOS ball bearing sprocket assembly is mounted as an idler on the tight side of the chain drive. It can be set on top or bottom of drive chain, whichever is the tight side. As the load increases, the arc of the chain becomes straight, and the spring tension on the fulcrum arm resists this force until a pre-set torque is reached. When the pre-set point is reached, the spring opens a micro switch that shuts off power from the motor—stopping the drive system. Starting torque generally determines the maximum load for proper spring tension adjustment. One half inch to one inch of chain deflection is required to activate the limit switch. When overload has been eliminated, the circuit will close and the motor can be re-started with a push button.

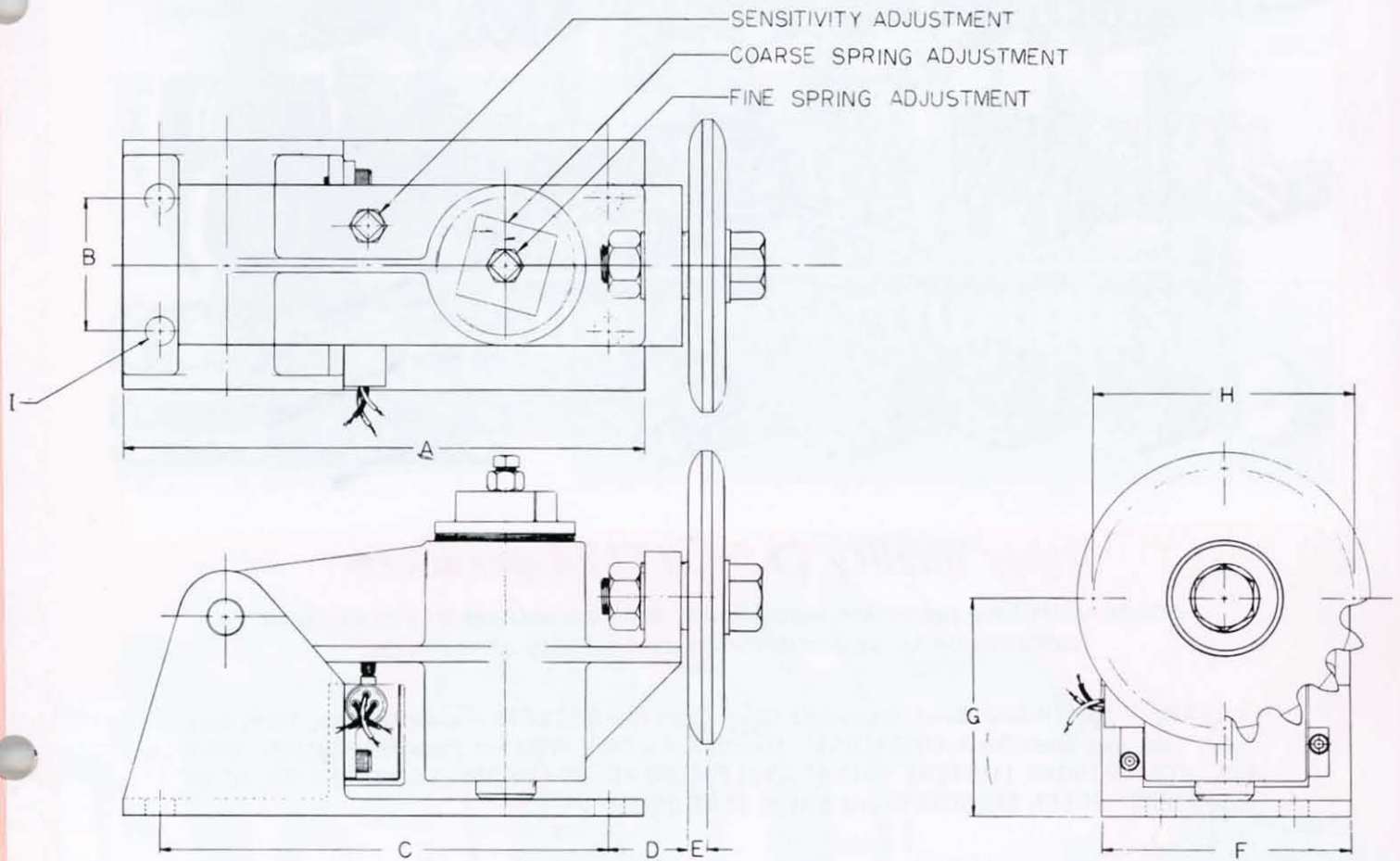

Catalog No.	Length of Base		Mntg. Hole Spacing-Width		Mntg. Hole Spacing-Length		Hole Center to Sprocket Face		Width of Unit		Base to Sprocket Center		Mntg. Hole Size	
	A		B		C		D		F		G		I	
	In.	mm	In.	mm	In.	mm	In.	mm	In.	mm	In.	mm	In.	mm
SOS-1	7½"	191	1¼"	32	6⅝"	168	⅞"	22	2⅞"	73	2½"	64	⅞"	11
SOS-2	9"	229	2¼"	57	7¾"	197	1½"	38	4⅜"	111	3⅜"	97	9/16"	14

#### SPROCKETS FOR SOS – 1

SPROCKET NO.	Sprocket Tooth Center E	Pitch Dia. H
35SOS 19	.083	2.278
41SOS 18	.113	2.879
40SOS 18	.125	2.879
50SOS 17	.156	3.401
60SOS 15	.218	3.607

#### SPROCKETS FOR SOS – 2

SPROCKET NO.	Sprocket Tooth Center E	Pitch Dia. H
80SOS 15	.281	4.810
100SOS 13	.312	5.223
120SOS 13	.437	6.268
140SOS 11	.437	6.211
160SOS 11	.562	7.099

#### WARRANTY

Dalton Gear Co. warrants product to be free from defect in material and workmanship for one year from date of shipment. The company will repair or replace F.O.B. shipping point, any item found to be defective upon inspection at Dalton factory in Mpls., MN within one year from date of shipment. No person, agent, or representative is authorized to give any warranty or make any representation contrary to the foregoing. Under no circumstances will the manufacturer be liable for any loss, damage, expense or consequential damage of any kind arising in connection with the use, inability to use, mis-use or mis-application of Dalton products.

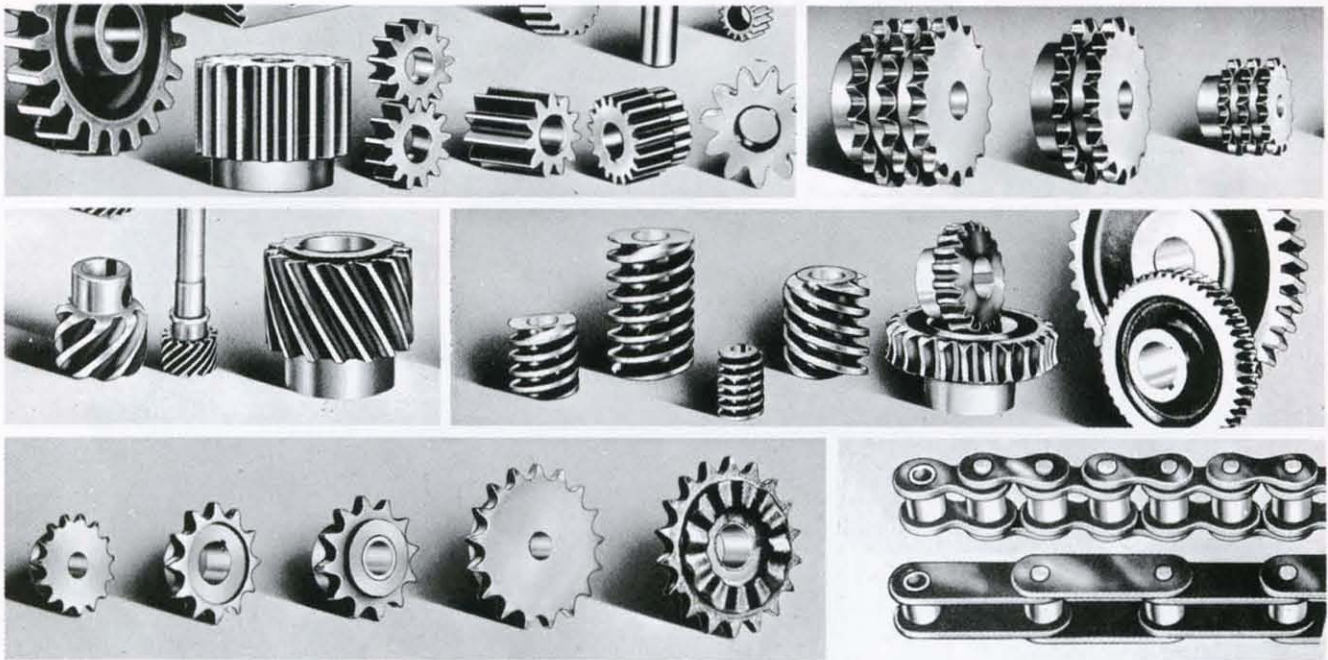

## *Other quality DALTON products*

Made with fine precision equipment and inspected to insure rigid adherence to specifications and quality standards.

★ GEARS – Spur, Helical, Bevel, Worms and Worm Gears ★ SPROCKETS – made to order, Stock Bore, Taper Lock and Shear Pin ★ COUPLINGS – Flexible Roller Chain, Rigid and Shear Pin ★ TIMING BELT PULLEYS ★ TORQUE LIMITERS ★ RIGHT ANGLE GEAR BOXES ★ WORM GEAR SHAFT MOUNTED REDUCERS ★ IDLER SPROCKETS and DRIVE TENSIONERS

**RIGHT ANGLE  
BEVEL GEAR UNITS**

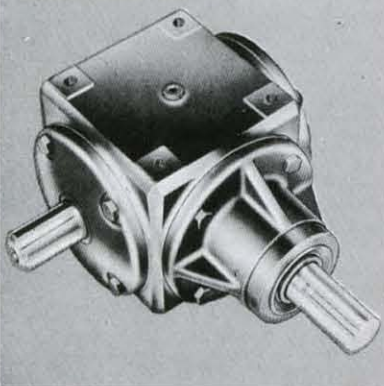

**SHAFT MOUNTED  
WORM GEAR REDUCERS**



**FRACTIONAL HORSEPOWER  
GEAR MOTORS**



**SPECIAL GEAR BOXES MADE FOR YOUR NEEDS**



**HELICAL & SPUR**

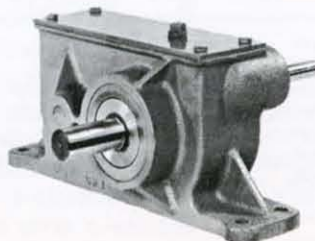

**WORMS & WORM GEARS**

